

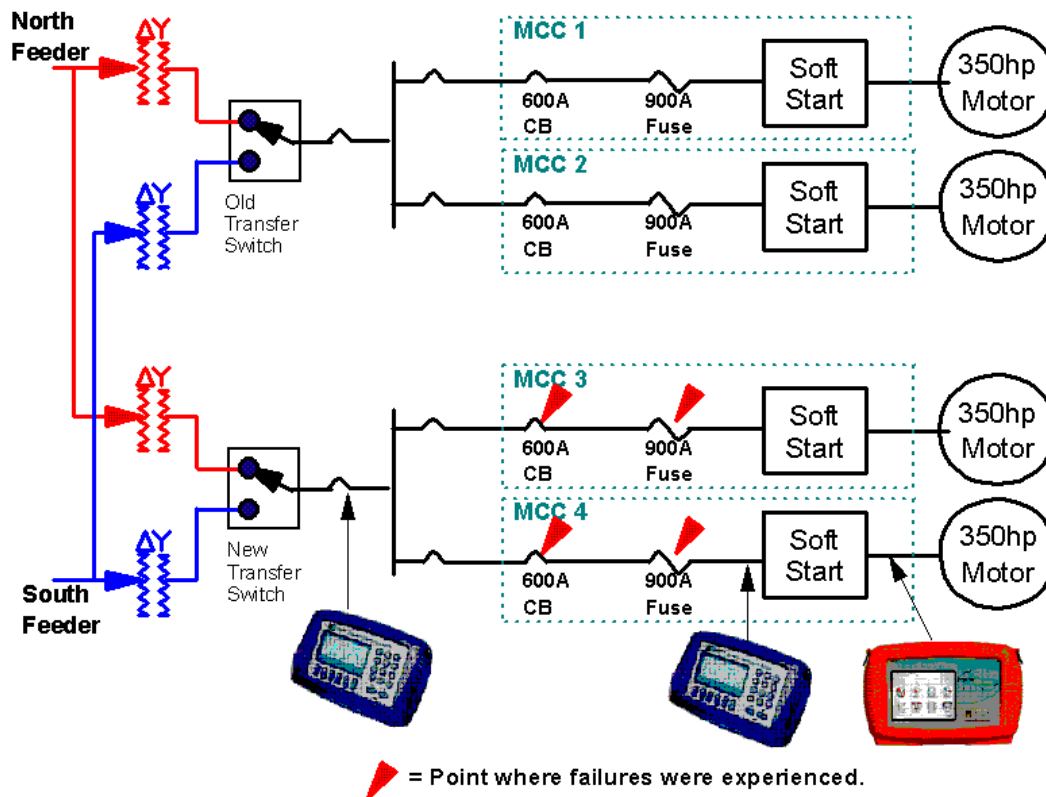
## Consulting Report Breaker Trip / Fuse Blowing Investigation MCC / Blower Motors

### Introduction / Background

The plant had recently completed installation of four new blowers as well as a new electrical service; associated switchgear and automatic transfer switch (ATS). Following installation blowers 3 and 4 served from MCC 3 and MCC 4 respectively, experienced several failures of phase A fuse and a breaker operation of the associated 600A MCC input breaker.

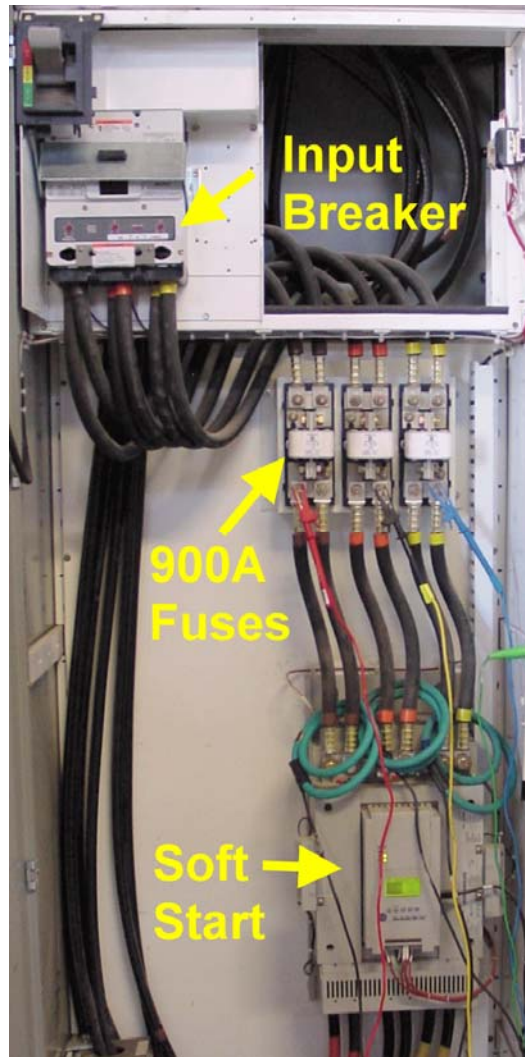
PowerCET Corporation was asked to aid in the investigation of the fuse/breaker problem associated with blowers 3 and 4

Figure 1 is a simplified diagram of the electrical distribution associated with the blower installation.



**Figure 1 - Simplified diagram of blower electrical distribution.**

Photo 1 shows the MCC cabinet components—main input circuit breaker, fuses (phase A which has blown several times) and the soft-start.



**Photo 1 - MCC cabinet showing components.**

## Methodology

Dranetz-BMI PP4300 power monitors equipped with Multi-DAQ Taskcards were installed at the load side of the new transfer switch and at the input of the soft-start in MCC 4. In addition a PowerGuide 4400 was installed on the output of the soft-start. See Figure 1 for monitor placement. The initial plan was to monitor the circuits for a 7-day period in an effort to determine the cause of the blown fuses.

## Key Findings & Recommendations

The following table summarized the operation of blowers 3 and 4 during the monitoring period from 10/7/2004 through 10/14/2004. The table illustrates that the problem is intermittent as there were no recorded problems from the period 10/7 @ 1300Hrs through 10/13 @ 0915Hrs. The respective blowers were cycled ON/OFF several times during the period with no reported problems either with blown fuses or tripped breakers. (Note: The table was color coded to make it easy to observe the over lap in blower operations.)

**Table 1 - Summary of MCC3 and MCC3 blower operations and problems.**

Date	MCC 3		MCC 4		Comment
	Time	Status	Time	Status	
10/7/2004		OFF	1300	ON	
10/8/2004	1612	ON			
10/9/2004			700	OFF	
10/9/2004					
10/9/2004			1635	ON	
10/11/2004			608	OFF	
10/11/2004	1245	OFF			
10/11/2004					
10/11/2004	1345	ON			
10/11/2004			1703	ON	
10/12/2004	629	OFF			
10/12/2004			1048	OFF	
10/12/2004					
10/12/2004			1501	ON	
10/12/2004	1639	ON			
10/13/2004			600	OFF	
10/13/2004	915	OFF			
10/13/2004					
10/13/2004	1433	ON/OFF			No Start
10/13/2004	1438	ON/OFF			No Start
10/13/2004	1439	ON			
10/13/2004					
10/13/2004	1829	OFF(Trip)	1829	ON/OFF	Trip
10/13/2004					
10/14/2004			1157	ON	
10/14/2004			1214	OFF	
10/14/2004					
10/14/2004			1241	ON	
10/14/2004	1400	ON/OFF	1400	OFF(Trip)	Trip

COMMENTS: The monitoring data for the monitors installed on the load side of the ATS and MCC 4 it was possible to compile the above chart showing that the blowers can be cycled ON/OFF without problems. Analysis of the monitoring data from the failures on 10/13 and 10/14 revealed that the ATS was transferring and a very large current surge was being generated.

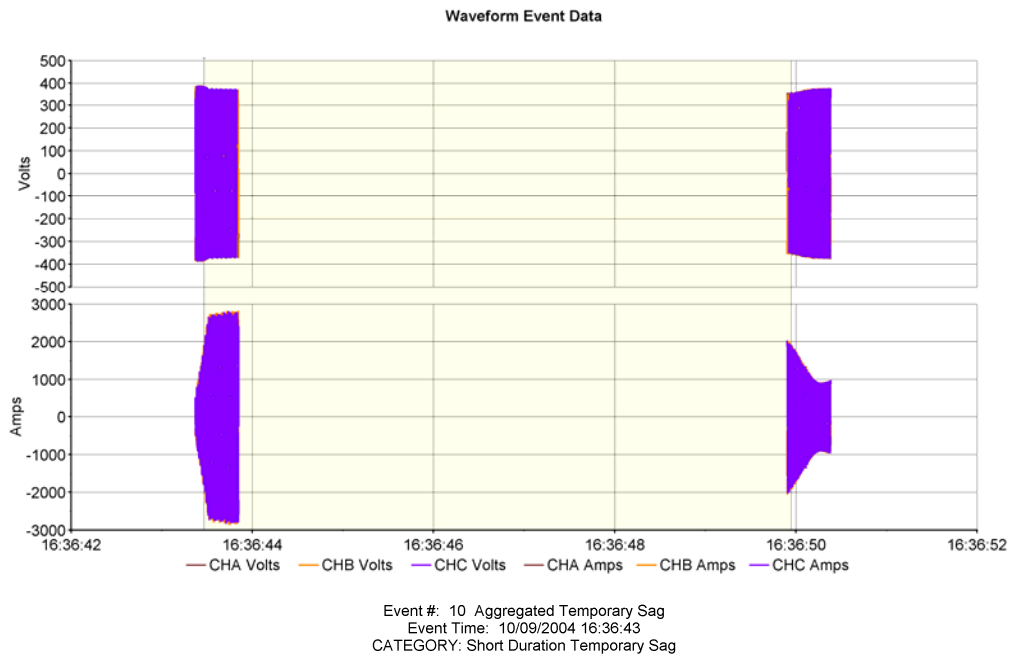
**Normal Blower Start-up**

The following table summarized typical inrush values associated with a successful start-up of a blower. Typical inrush duration is slightly less than 7-seconds (420-cycles). (Note: Using the delta measurement function in Dranview allows for accurate measurement of the total inrush period...the 420-cycle inrush period was much longer than anyone thought). The minimum voltage sag during inrush was just above the 85% voltage dropout setting of the new ATS—resulting in a “good” start-up.

**Table 2 - Inrush values associated with normal blower start-up.**

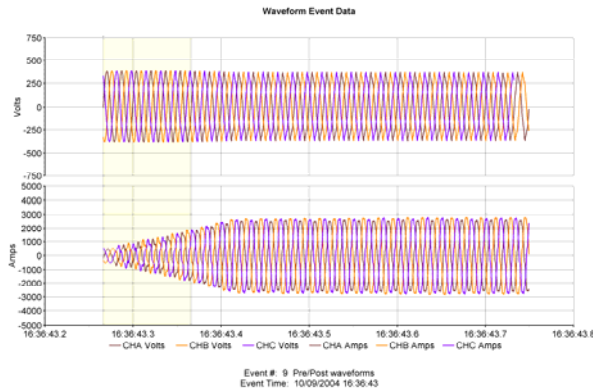
	Phase A	Phase B	Phase C
Maximum Current	1923 Arms	2065 Arms	2333 Arms
Maximum Peak Current	2688 Apeak	2868 Apeak	2849 Apeak
Minimum Voltage	238 V (86%)	237 V (85.5%)	237 V (85.5%)

Figures 2, 3 and 4 show the waveform envelope and associated inrush voltage and current waveforms of a normal (successful) start-up of a second blower with one blower already operational.

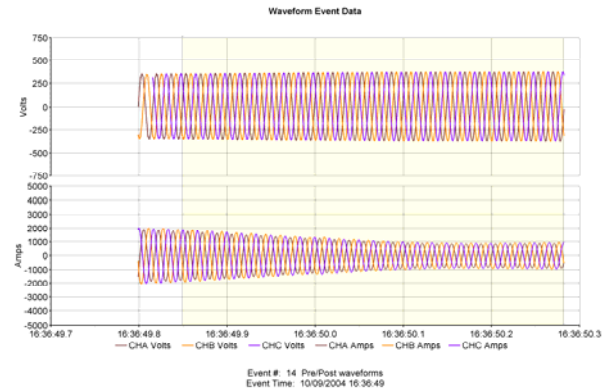


**Figure 2- - Waveform envelop of normal successful start with a second blower already operating.**

COMMENT: The Dranetz-BMI PP4300 w/Multi-DAQ, PG4400 and PX5 all have the ability to capture long record lengths—many cycles—whenever an event is triggered. This is an invaluable feature when troubleshooting this type of problem or when trying to determine a loads inrush characteristic. Had the 7-second inrush period been know prior to initial programming the post-cycle capture settings could have been expanded to capture the complete waveform envelope. In Figure 2 above the threshold settings were sufficient to get the start and end of the inrush which allowed for the inrush duration to be accurately measured.



**Figure 3 - Inrush waveforms for start-up of blower--see figure 2.**



**Figure 4 – End of inrush for start-up of blower—see figure 2.**

**Blower Start-up Failure (Breaker Trip)**

On 10/13 @ 1433Hrs blower 3 took three attempts to get it operational. All voltage and current levels appeared to be satisfactory and, from an electrical supply standpoint, there is no apparent reason as to why the blower took three attempts to start.

On 10/13 @ 1829Hrs, while blower 3 was operating, an attempt was made to start blower 3. Almost immediately blower 3 tripped-off and blower 3 failed to start.

On 10/14 @ 1400Hrs a similar problem was experienced, only this time blower 3 was operating when an attempt was made to start blower 3. The results were the same as experienced on 10/13 in that the running blower tripped-off and the other blower failed to start.

The following table summarized typical inrush values associated with an unsuccessful start-up of a blower: Typical inrush duration is slightly less than 7-seconds (420-cycles). The values in Table 3 are very close to those shown in Table 2 for a successful blower start-up. In this case the minimum voltage levels experienced during inrush were slightly under the 85% voltage dropout setting of the ATS causing the ATS to transfer resulting in a very high current surge because of the phasing problem causing the input breaker to trip.

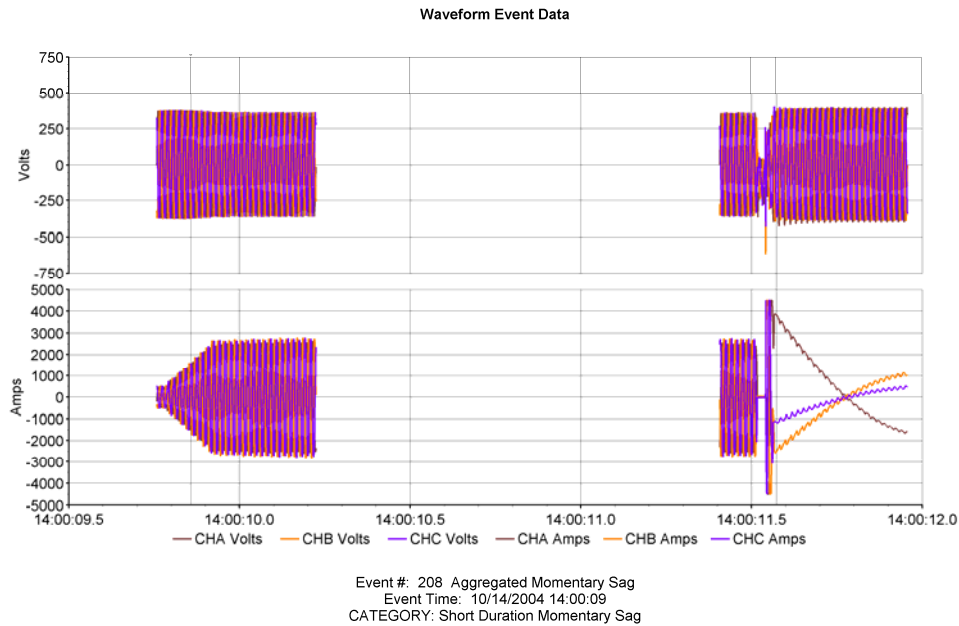
**Table 3 - Inrush values associated with abnormal blower start-up.**

	Phase A	Phase B	Phase C
Maximum Current	1878 Arms	2032 Arms	2004 Arms
Maximum Peak Current	2629 Apeak	2820 Apeak	2804 Apeak
Minimum Voltage	233 V (84%)	233 V (84%)	233 V (84%)

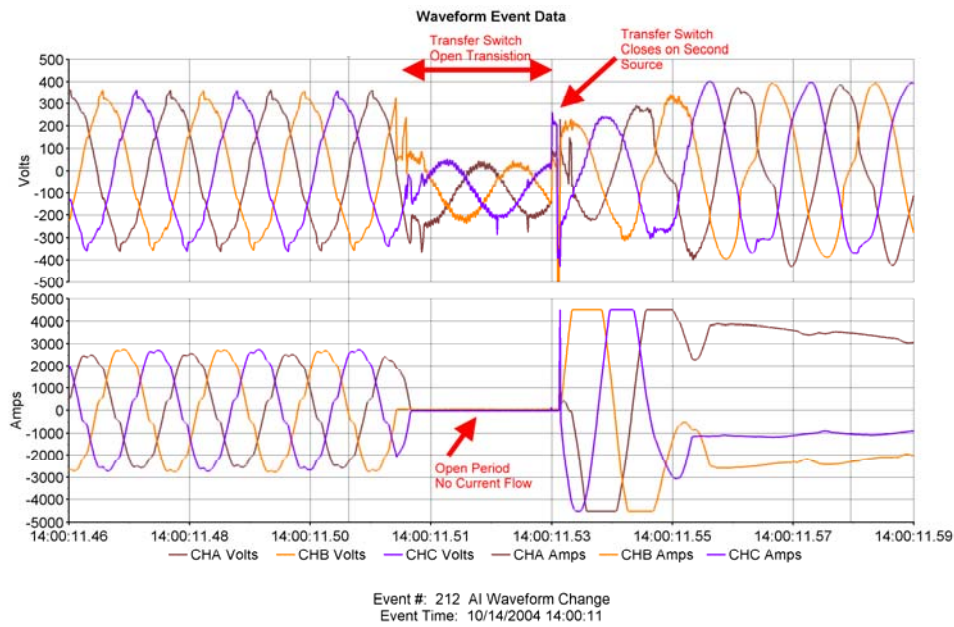
The following figures—5 through 10—are power monitor waveform data from the failure occurring on 10/14 @ 1400Hrs and graphically illustrate what is happening.

Figure 5 shows the waveform envelope associated with blower 4 tripping off at the time blower 3 was being started. Careful analysis of the waveforms indicates that after about 1.7-seconds (100-cycles)

something causes the Automatic Transfer Switch (ATS) switch to transfer to the alternate (second) source. At the time that the ATS closes on the second source a current surge, well above the instantaneous setting of 3000A for the MCC 600A input breaker, is experienced causing the 600A breaker in the MCC to trip.

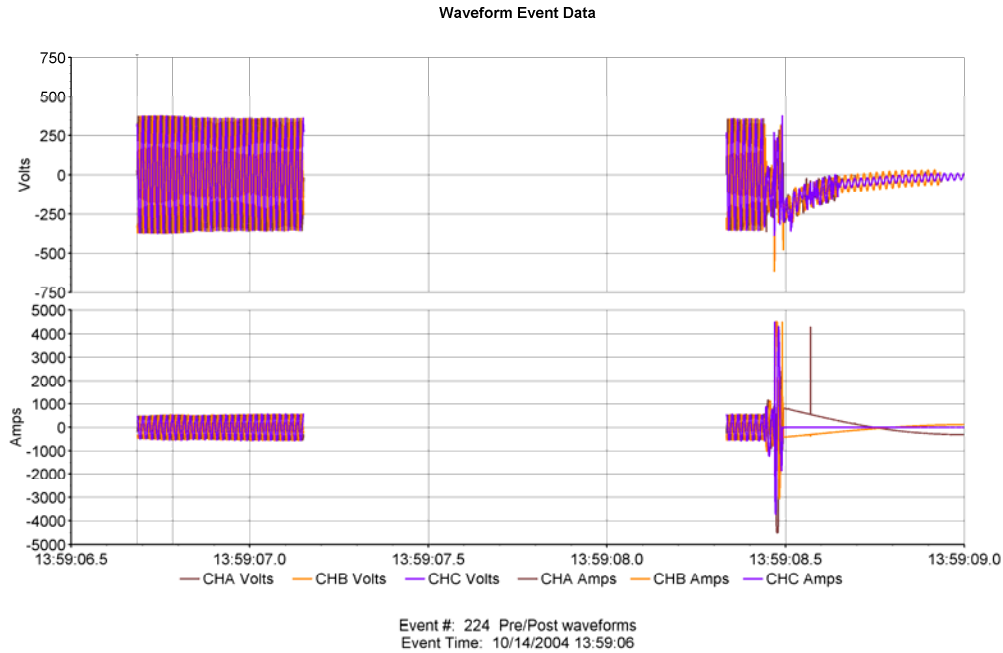


**Figure 5 – Waveform envelop at load side of ATS showing open transition and current surge associated with second source.**

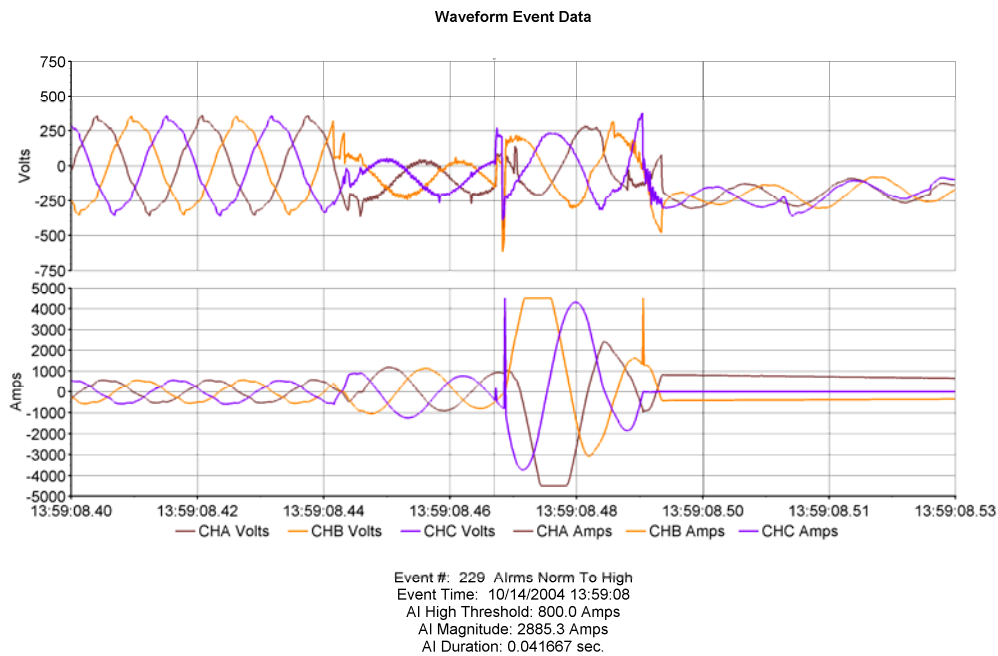


**Figure 6 – Detailed waveform from figure 5 showing open transition and connection to second source.**

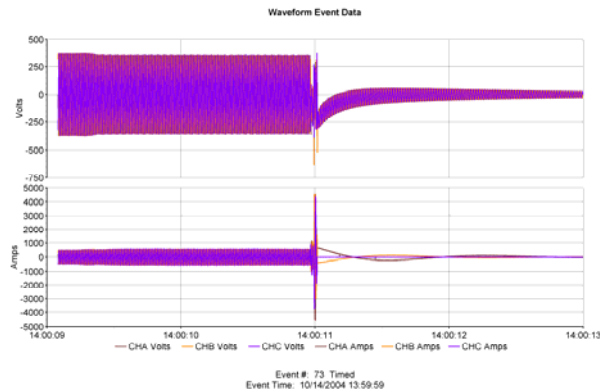
COMMENT: One of the great features of Dranview is the ability to copy and export event screens to other graphics programs. Adding annotation enhances the information and helps non-technical (or inexperienced) readers to better understand what occurred and the analyses.



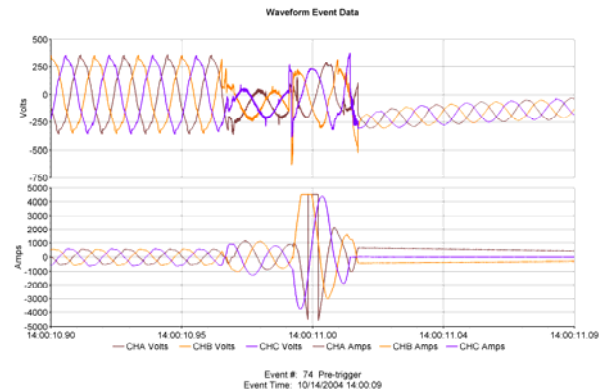
**Figure 7 - Waveform envelop from MCC 4 at the time blower 3 was attempting to start. Note 4000+ Amp current surge that operated MCC 4 600A input breaker.**



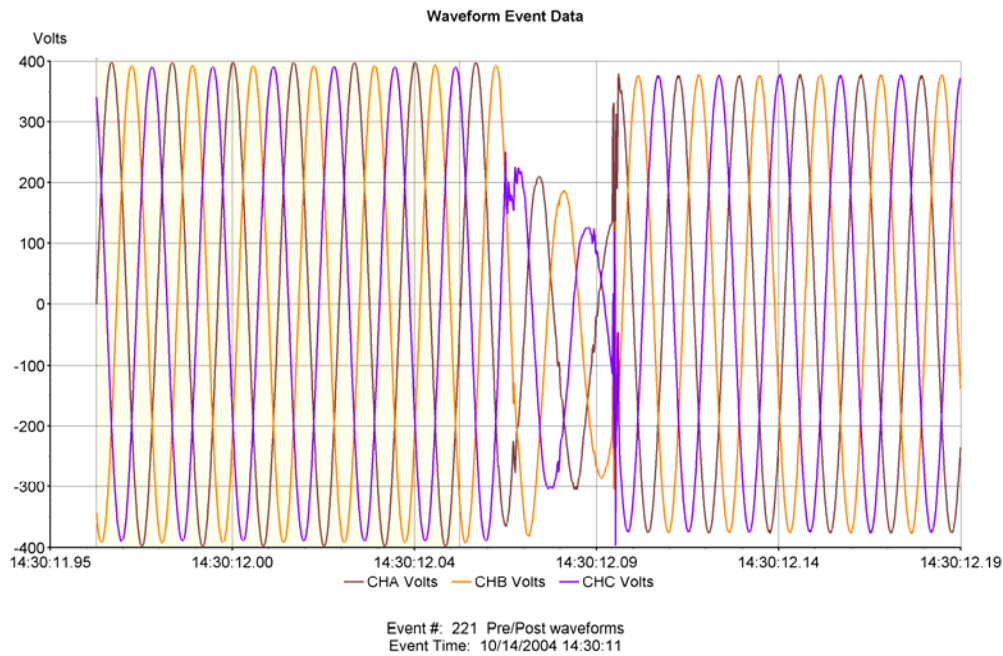
**Figure 8 – Detailed waveform from figure 7 showing 4000+ Amp current surge.**



**Figure 9** Waveform envelop of MCC 4 soft-start output at time of breaker tripping—refer to figures 7 and 8.



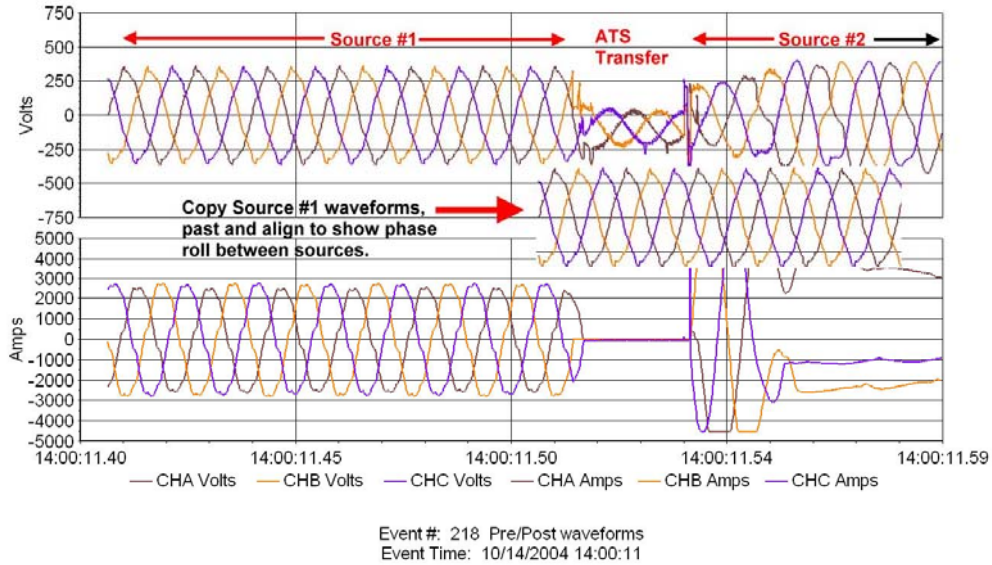
**Figure 10** – Detailed waveform recorded on MCC 4 at the output of the soft-start at the time of breaker tripping—refer to figures 7, 8 and 9.



**Figure 11** – ATS return to preferred source approximately 30-minutes following blower failures at 1400Hrs.—refer to figures 7 through 10. The retransfer back to the preferred source was programmed option.

### ATS Source Phase Inconsistency

Careful analysis of the event waveforms recorded during the breaker tripping revealed that there appeared to be phase transposition (rotation/rolling) between the two sources—north and south utility feeds—connected to the ATS.



**Figure 12 – Detailed waveform event data from failed start-up and breaker trip showing phasing problem between ATS sources. (Waveforms from source #1 were copied, pasted and aligned to better illustrate phase “roll” between sources).**

COMMENT: Copying the Dranview event data and importing it into another graphic program allow some enhancement of the information—in this case copying, pasting and aligning the Source #1 voltage waveform to better illustrate the phase “roll” between Source #1 and #2. It all comes down to the “a picture is worth a thousand words.”

A power monitor was connected to each of the sources to determine (1) phase rotation and (2) phase relationships—A to A, B to B, etc.

The results of the testing determined that while the phase rotation (ACB) is the same for both sources the relationship of the phases across the ATS is rotated 120-degrees. Figure 13 is a waveform graphic with phasor showing that phase A of source #1 is related to phase C on source #2. Photo 2 shows the relative ATS phase relationships for source #1 and #2.

COMMENT: On of the great features of the Dranetz-BMI family of power monitors is their fully independent channels. It allows the instrument to be configured in a variety of ways that other monitors with a shared common can not do. In this case connecting the phases of Source #1 to the + (high-side) of the monitor and the phases of Source #2 to the – (low-side) provided immediate visual verification of the problem and also documented that it was not a simple transposition between two phases. The benefit of doing this demonstration for the local plant personnel was that it improved their understanding of the problem.

COMMENT: A second demonstration was performed for the plant personnel by connecting channels A, B and C of the monitor to Source #2 and then connecting phase A of Source #1 to channel D. Viewing the phasor diagram further visually illustrated the problem. See Figure 13 below.

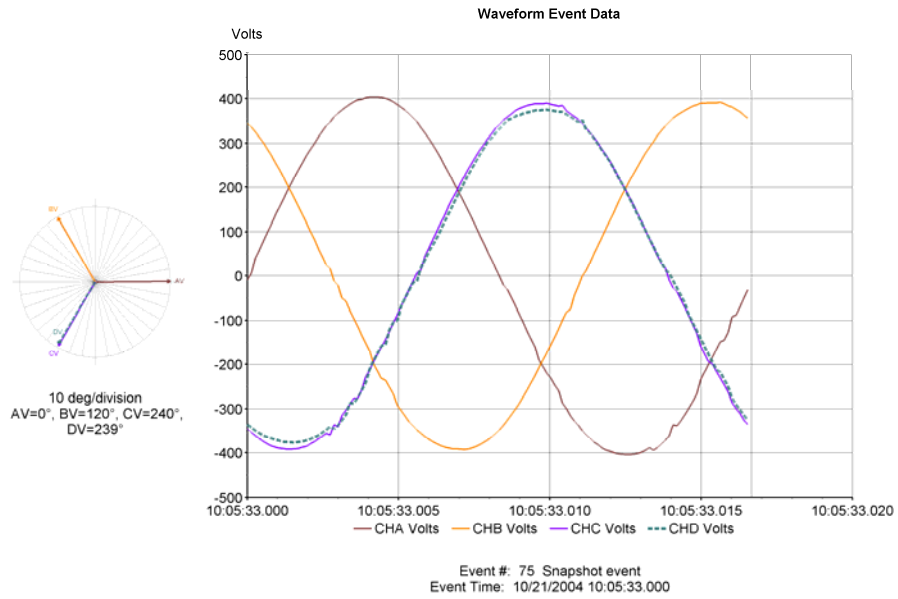


Figure 13 – Voltage waveforms associates with ATS source #2 with channel D connected to phase A of ATS source #1 which tracks with phase C of source #2.



Photo 2 - New transfer switch showing phase termination rotation between sources.

There is a high likelihood that the blown fuse and breaker tripping experienced earlier are related to the wiring error associated with the new ATS. Both the ATS and the controller (PLC) for each blower have various thresholds settings and they may be set a little sensitive for this application and certainly need to be coordinated.

The ATS is set for “rapid” transfer—one-cycle open transition—and with the phase inconsistencies between the sources and the inductive (magnetic) nature of the load, the load is going to react adversely to the application of an out of phase stiff voltage source resulting in large current surges which are well above 4000A.

**RECOMMENDATION:** (1) Correct the phase inconsistencies between the respective sources of the ATS. It is actually more like the phases were “rolled” (or rotated) as the correction involves all three-phases. The inconsistency could be in either of the sources (services) or the actual wiring of the ATS. While it is common practice to verify phase rotation it is no guarantee that the ATS inputs are wired with the proper phase relationships—as this experience demonstrates. Phase rotation should always be checked, and in addition a voltage reading should be made between corresponding phases of the respective sources—a near zero value should be obtained if the phase relationships are correct. In the case of the new ATS the readings of A to A, B to B and C to C were all in the 480V range indicating a phase relationship wiring problem. (2) Retest and document cycling of equipment in various modes following correction of ATS wiring.

**CORRECTIVE ACTION / DISPOSITION:** The Utility Department rolled the phases associated with the south feed transformer to correct the phase inconsistencies between the sources of the new ATS. A Dranetz-BMI PowerGuide 4400 was connected to each source of the new ATS to verify correct phase relationships and phase rotation after completion.

The program setting of the new ATS were checked by ATS service representative. The following is a summary of the options settings of concern and the action taken:

ATS Option	Setting	Corrective Action
Phase Rotation Monitor	ON (C-B-A, correct)	None
In-Phase Monitor Enable	OFF [1]	Reset to ON
Voltage Dropout	85% of 480V [2]	Reset to 80%
Voltage Pickup	90% of 480V	Reset to 85%
Time Delay	0 Seconds [3]	Reset to 15-seconds

**Notes:**

[1] Had the IN-PHASE MONITOR been enabled it would have inhibited the transfer of the ATS to the second source.

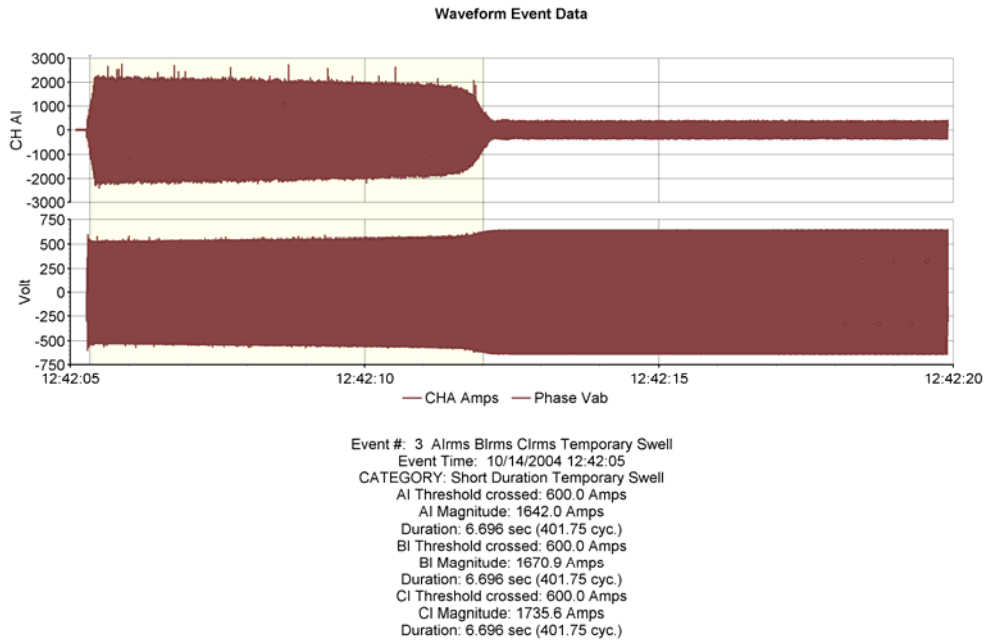
[2] In addition the VOLTAGE DROPOUT threshold was set very sensitive, which caused the ATS to transfer on some blower motor startups. Voltage measurements recorded during start-up at the 85% threshold setting which is the reason the problem was intermittent.

[3] The TIME DELAY was initially set to its minimum, no delay, which did not provide sufficient time for the blower controller to dropout and turn the soft-start off.

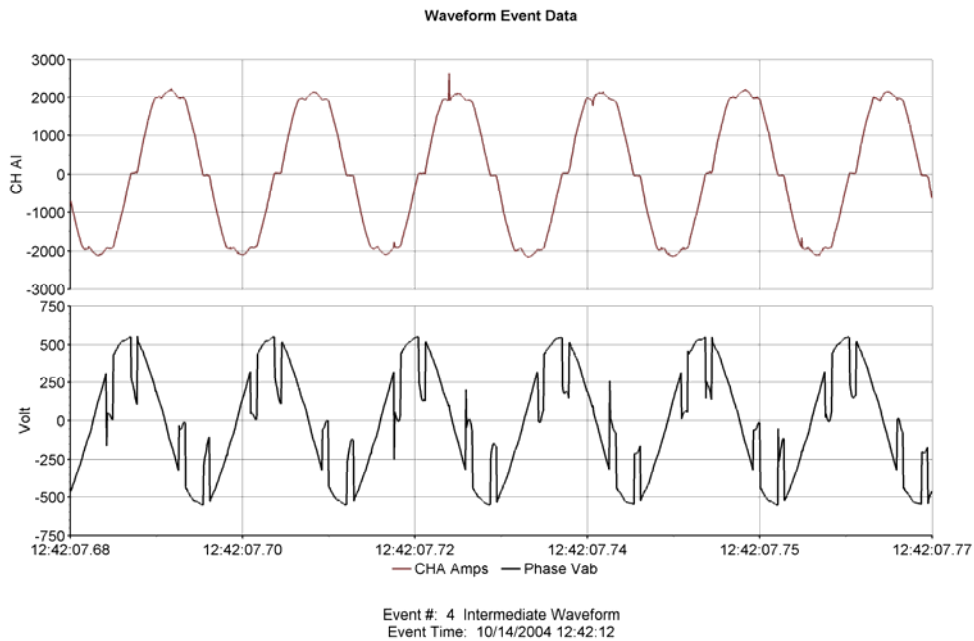
Had the IN-PHASE MONITOR, VOLTAGE DROPOUT or TIME DELAY been set to the values shown under corrective action the breaker tripping/fuse blowing problems would probably not have been experienced and the phase inconsistency between sources gone undiscovered for now. By identifying and correcting the problem now the plant has most likely avoided some potentially serious future problems.

### Soft-Start Performance

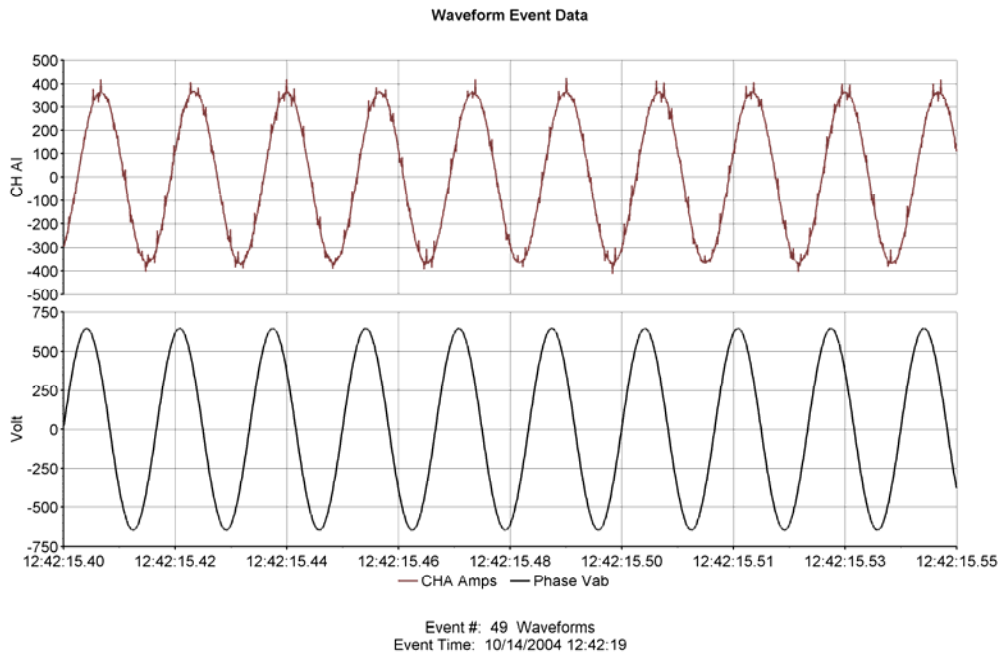
The following three figures, recorded with the Dranetz-BMI PowerGuide 4400, document the inrush characteristics and waveforms of the voltage and current at the output of the Soft-Start.



**Figure 14 - Waveform envelop for normal start-up of blower 4. Measurements taken at output of soft start.**



**Figure 15 - Current and voltage waveform during inrush with soft-start active. Measurement taken at output of soft-start.**



**Figure 16 - Current and voltage waveforms during normal blower operation after inrush and soft-start operation. Measurement taken at output of soft-start.**

**COMMENT:** The performance of the soft-start was documented, at the request of the client, as there was some initial concern that the problem may have been associated with “harmonics” at the output of the soft-start. There is a tendency “rush to judgment” and blame harmonics for most any problem that is not immediately obvious.

**Permanent Power Monitoring**

At present, other than a panelboard meter, there is no permanently installed power monitoring equipment. The critical nature of the facility and the multiple service feeds combined with multiple transfer switches forms a complex network that requires real-time information to manage the electrical environment.

The least costly configuration would be to install two power monitors, one each on the load side of the appropriate ATS, along with remote indications as to the source selected at that time. While this does provide information relative to operational loads this approach does not guarantee that the standby source would be monitored under all operational configurations.

The preferred configuration would be to have each source monitored as well as the output of each ATS. This configuration requires more equipment but provides superior information and would be a great aid in troubleshooting and documenting the level of service for each source.

**RECOMMENDATION:** Design and install a permanent power monitoring network for the facility.

**Summary**

It appears that the fuse and breaker problems experienced on blowers 3 and 4 are related to the option settings of the new ATS and the associated phase inconsistencies between the respective sources. Once the ATS wiring is corrected then all blowers should be instrumented and tested in various configurations to ensure reliable operation.



Why the ATS is activated intermittently is a function of the electronic control thresholds as there does not appear to be any electrical service conditions that vary significantly from a "good" startup and problem. Had the ATS source wiring problem not occurred, the equipment probably would not have experienced operational difficulties as there appears to be sufficient hold-up time for the blowers and associated control equipment to ride-through a single-cycle open transition from the ATS.

At present the facility has no historical monitoring capability on which to base reliability performance on the existing services. In addition to historical data permanently installed monitoring systems are a great aid in troubleshooting and determining the direction of a fault when problems are experienced making problem resolution both faster and less costly. Installation of a permanent power monitoring network for the facility is strongly recommended.

Report prepared by:

Bruce Lonie  
President, PowerCET Corporation

**Disclaimer**

The information contained in this document is provided for educational purposes only as an example on how to incorporate power monitoring data and other observations into a report format. It is not intended to provide consulting advice for any specific problem or situation. This is a copyrighted document and intended for individual use and should not be reproduced or distributed in any form without specific written permission from PowerCET Corporation.