

PowerCET Corporation
3350 Scott Blvd., Bldg. 55 Unit 1
Santa Clara, CA 95054
Voice: 408/988-1346
Fax: 408/988-4869
E-mail: consulting@powercet.com
URL: <http://www.powercet.com>



Consulting Report ATE Product Testing Lab Noise Problem ABC Industries Somewhere Valley, AK

Introduction

PowerCET Corporation was retained to investigate an apparent electrical interference problem in the Product ATE Lab, which was causing interment communications problems with the Product under test. The nature of the interference was such that it was preventing the timely completion of test and verification resulting in delayed shipments.

The Product test bays employ a multi-conductor TTL data link with the unit under test. Measurements by test engineers using a grounded oscilloscope and conventional voltage probe recorded some voltage signals between equipment grounds and the electrical ground.

Methodology

A PowerCET MainEvent monitoring system was installed along with a conventional power monitor to record electrical interference in the ATE Lab area.

The MainEvent system consists of a 4-channel digital storage oscilloscope (DSO), high frequency current probes and special voltage probes. In addition a spectrum analyzer (SA) was included to record conducted frequency domain events. The equipment is connected to a laptop controller, which automates the data acquisition process.

A time of arrival technique was planned to aid in the identification of interference sources, but this proved difficult to implement due to the lack of equipment grounding conductors in the electrical distribution system.

A site survey and monitoring program were conducted the week of April 6, 2000.

Key Findings

1. Equipment Grounding System

The ABC facility is a steel building with multiple electrical distributions all of which employ conduit only grounding—i.e., few, if any, equipment grounding conductors are run in the conduit with the circuit conductors. The ATE Lab area is served by at least three different electrical distributions: (1) 480/277Vac for lighting, a 3-phase 240V delta system (environmental chamber fan/blower assemblies), and the 208/120Vac UPS electrical distribution (electronic test and computer equipment).

Figure 1 is a graphical attempt to illustrate present grounding and distribution system with common conduit connection. The mounting brackets for the conduit are common which effectively ties all electrical systems together through the building. The result is that interference generated anywhere in the building has the potential to flow through the various conduits in the ATE Lab area.

In addition the integrity of the equipment grounding system is dependent on the various physical connection methods used in the construction of the electrical system—screw thread, clamp, compression sleeve, etc. All of these methods of connection have their problems and should never be used as the sole grounding means in an electronic installation.

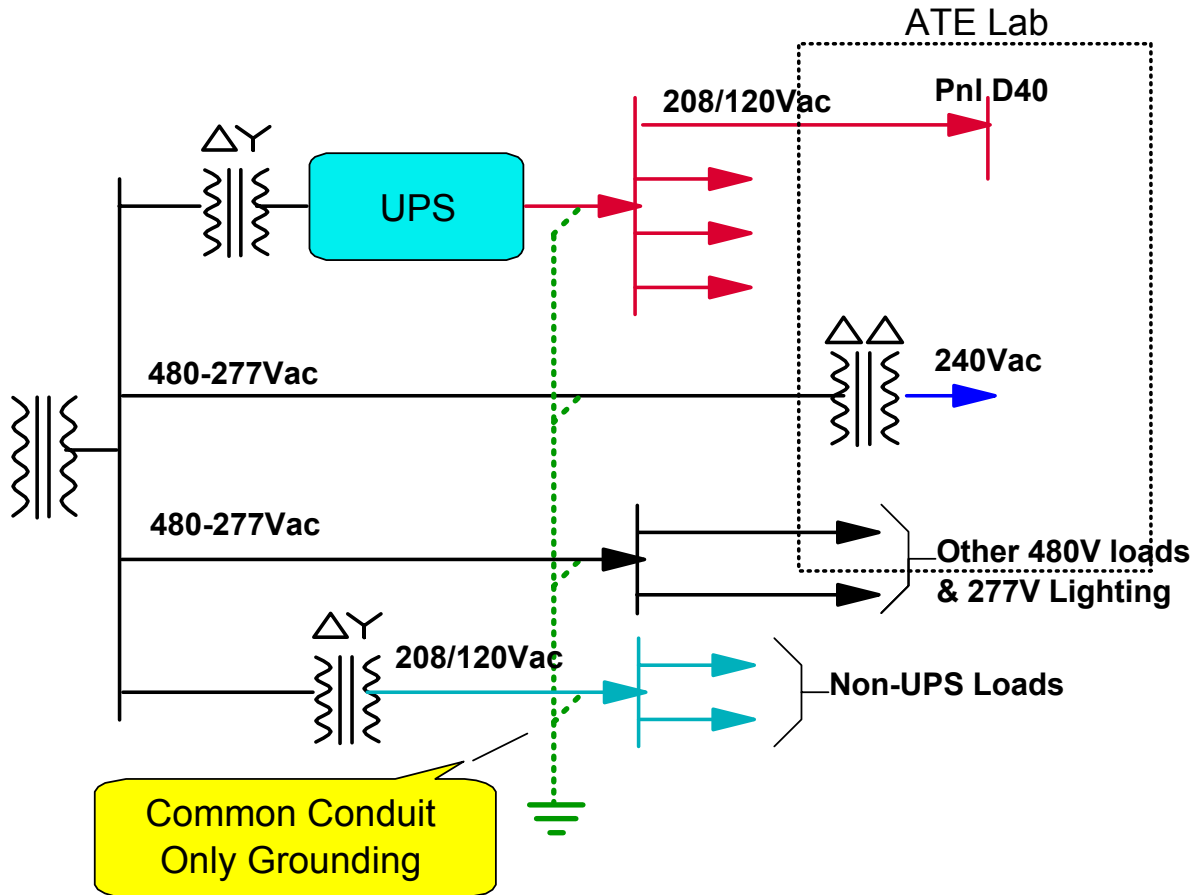

Figure 1 - ABC facility electrical distribution--conduit only grounding.

2. Inspection of Panelboard D40 (ATE Lab)

A visual inspection of panelboard D40 revealed circuits 22-24-26 were installed with a green-wire grounding conductor (isolated ground). The associated circuits terminated in the Environmental Lab across the hallway. Further inspection of the duplex receptacles installed on the circuits found one that was NOT an Isolated Ground (IG) type and this resulted in connection of the conduit grounding system with the Isolated Ground conductor terminated in D40. (Facility electricians removed the offending duplex receptacle at approximately 3:10PM on 4/27/2000.)

Photo 1 below shows the offending green wire IG conductor—red arrow. (See recommendations for practices regarding installation of branch circuits between zones.)

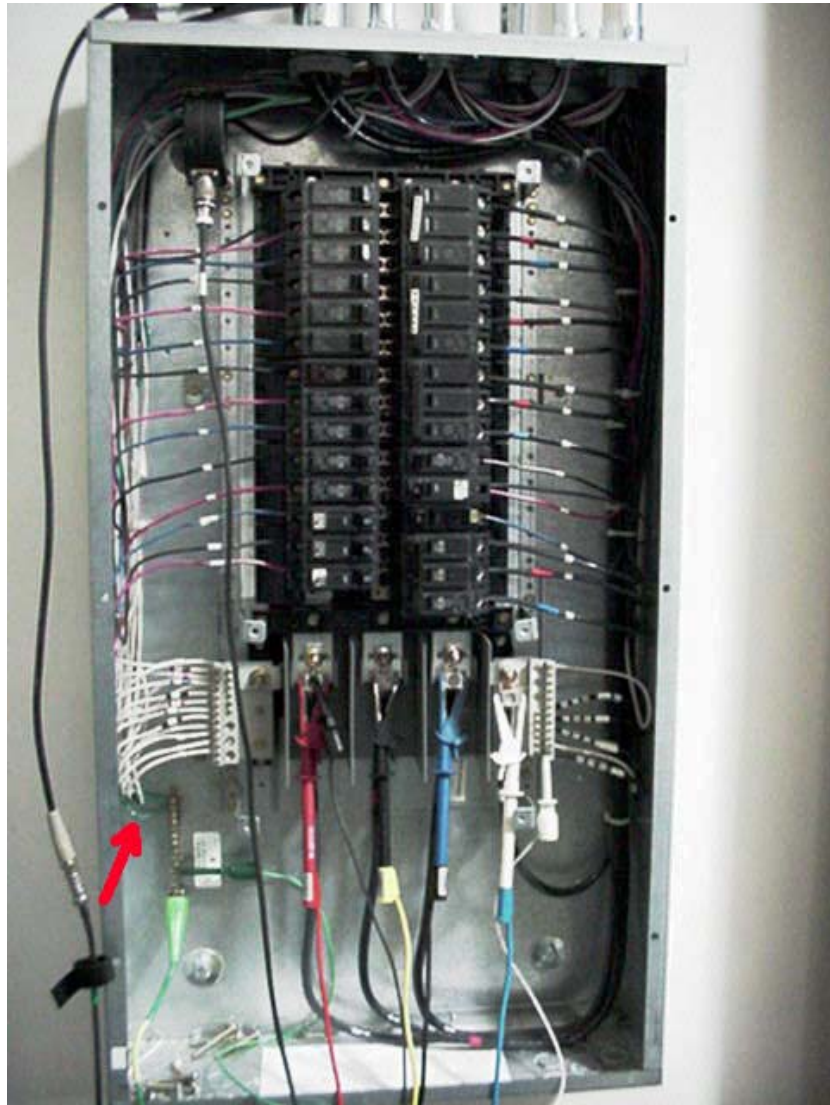

Photo 1- Panelboard D40 ATE Lab showing green wire IG conductor terminating in Environmental Lab across the hallway.

3. High Frequency Monitoring (MainEvent System)

The MainEvent monitoring system was installed adjacent to panelboard D40 in the ATE Lab.

The monitoring system consisted of the following equipment:

- Tektronix TDS540C 4-ch Digital Storage Oscilloscope set for logic OR trigger with 3-each 91550-1 current probes (10kHz – 100MHz) and 1-each Oneac LineViewer voltage probe (5kHz-5MHz).
- Hewlett-Packard 8591E Spectrum Analyzer with a 91550-1 current probe (10kHz – 100MHz).
- Dranetz-BMI 658 4-ch Power Quality Analyzer (7.2kS/s lower frequency and 1.8432 MS/s high frequency).

The table below shows the monitoring points and configuration of the MainEvent system during the monitoring period.



MainEvent Monitoring System

DSO Channel #	Probe Type	Monitoring Point 4/25/2000 (1B)	Monitoring Point 4/25/2000 (1C)	Monitoring Point 4/26-27/2000 (1D)
1 (Current)	HF Current Probe	IG Gnd Cond D40	IG Gnd Cond D40	IG Gnd Cond D40
2 (Current)	HF Current Probe	LT Flex TS4	LT Flex XYZ/TS	LT Flex TS4
3 (Current)	HF Current Probe	Green Wire TS4	TTL Data Link XYZ/TS	TTL Data Link
4 (Voltage)	Line Viewer	N-to-G Pnl D40	N-to-G Pnl D40	N-to-G Pnl D40
SA	HF Current Probe	LT Flex TS4	LT Flex XYZ/TS	LT Flex TS4
658 PQA	Channel Type			
A	Differential Voltage	Phase A-to-N Pnl D40	Phase A-to-N Pnl D40	Phase A-to-N Pnl D40
B	Differential Voltage	Phase B-to-N Pnl D40	Phase B-to-N Pnl D40	Phase B-to-N Pnl D40
C	Differential Voltage	Phase C-to-N Pnl D40	Phase C-to-N Pnl D40	Phase C-to-N Pnl D40
D	Differential Voltage	N-to-G Pnl D40	N-to-G Pnl D40	N-to-G Pnl D40

Figure 2 below shows one of the larger interference events recorded by the DSO during the initial monitoring period.

In Figure 2 channel 1 is the signal on the IG conductor that terminated on the receptacles from the Environmental lab the corresponding signals on the grounds, channels 2 and 3, associated with the TS4 test station demonstrate how the signal propagated in the conduit grounding system. Channel 4 is the corresponding neutral-to-ground voltage in the 5kHz-5MHz bandwidth.

The Dranetz-BMI 658 Power Quality also recorded a series of neutral-to-ground voltage impulses at the same time as the event in Figure 2, the largest of which was approximately 51 volts peak-to-peak—see Figures 4 and 5. Figure 4 is the neutral-to-ground event and Figure 5 is an expansion of the largest of the impulses in Figure 4. There was not a corresponding line-to-neutral event recorded which indicates that the signal is ground based—HF current probes confirm the current flowing in the various grounding conductors and conduit.

Figure 3 is an event, which was recorded at 9:41AM on 4/26/2000, and in this instance the monitoring system was connected to the XYZ/TS test station with channel 3 monitoring the TTL data link between the test station and the UUT (Unit Under Test). Again there are significant signals present on the other grounding conductors—channels 1 and 2—as well as a voltage signal recorded on channel 4—neutral-to-ground at panelboard D40. This signal is the type that has the capability to disrupt digital communications signals because of the duration and the burst (repetitive) characteristic. In all likelihood the path through the TTL link and UUT is capacitively coupled, as the signals appear to have higher frequency characteristics—shorter rise-times. (Note: This characteristic was noted in other recorded interference signals on the TTL data link.)

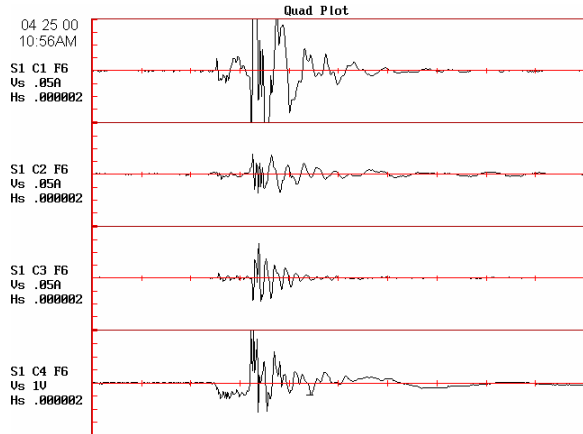

Figure 2 - High frequency ground based interference. Ch1=Ground current in D40-Ckts 22-24-26 green wire ground; Ch2=Ground current in LT Flex to TS4; Ch3=Ground current in green wire in power panel of TS4; and Ch4=Neutral-to-Ground voltage in D40 (5kHz-5MHz bandwidth).

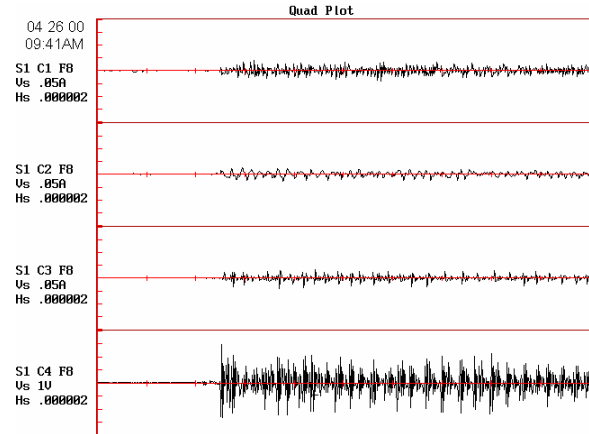

Figure 3 - High frequency ground based interference. Ch1=Ground current in D40-Ckts 22-24-26 green wire ground; Ch2=Ground current in LT Flex to XYZ/TS; Ch3=Interference signals in TTL data link between test equipment and UUT in XYZ/TS; and Ch4=Neutral-to-Ground voltage in D40 (5kHz-5MHz bandwidth).

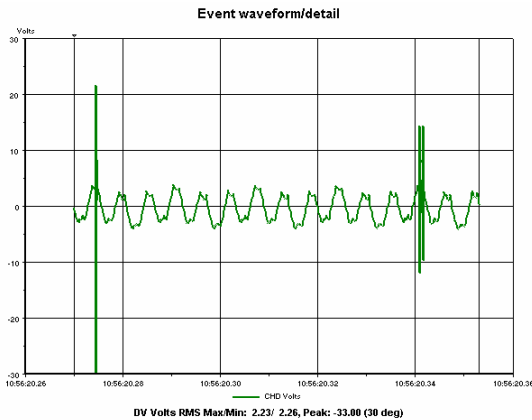

Figure 4 - Neutral-to-ground power monitor event corresponding to signals in Figure 2.

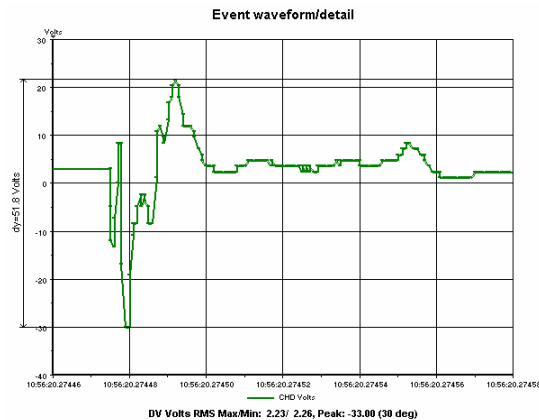

Figure 5 - Expanded neutral-to-ground power monitor event depicted in Figure 4.

In Figure 6 the only significant signal recorded was on channel 3, which is the TTL data link on test station TS4. The graphic to the right, Figure 7, is an expansion of the signal on channel 3 from Figure 6. The ringing frequency of the recorded events ranged from approximately 5MHz to 8MHz and may be alisased. The lack of significant signals on the other channels indicates that the source of interference recorded on channel 3 may be in the test station equipment.

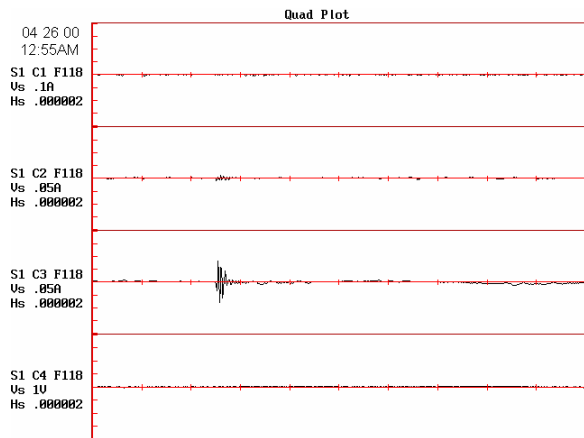

Figure 6 – Interference signal (current) on TTL data link TS4 test station.

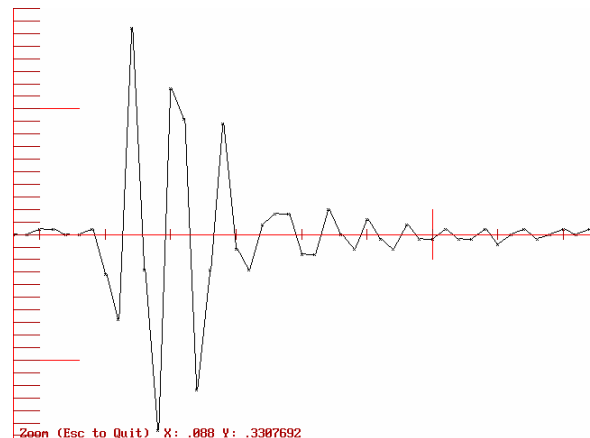

Figure 7 – Expansion of signal (current) on channel 3 from Figure 6—TTL data link.

Figure 8 is a set of signals similar to those in Figures 2 and 3 in that they are entering the ATE Lab via the equipment grounding (conduit) system and then propagated throughout the area including the TTL data link. Figure 9 is an expansion of the signal on channel 3,

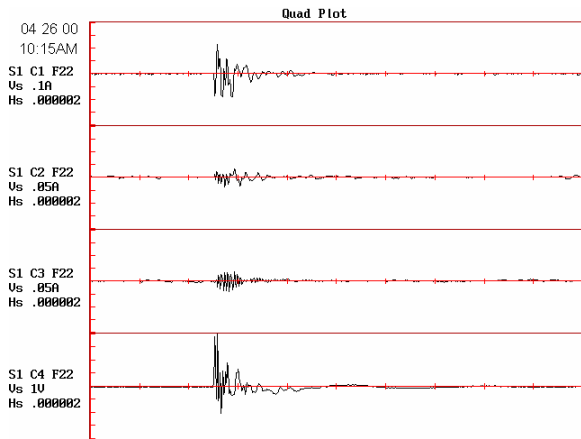

Figure 8 – Interference signals associated with ATE station TS4.

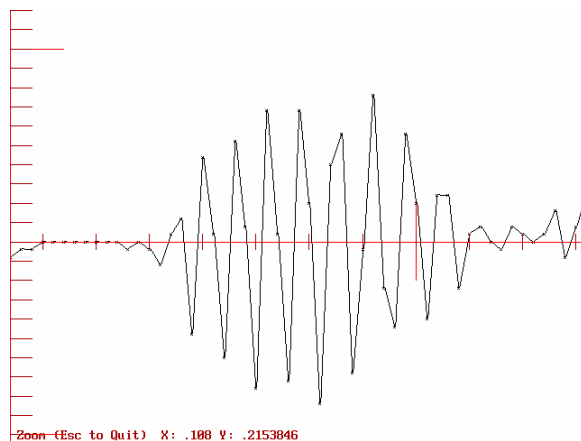

Figure 9 – Expanded interference signal, channel 3, TTL data link test station TS4.

The MainEvent monitoring data confirms the presence of a complex series of ground loops associated with the buildings electrical distribution—specifically the building conduit system. This situation combined with the extension of branch circuits from panelboard D40 to the Environmental Lab across the hallway appears to have created a significant signal path into the ATE Lab. Removal of the IG to conduit connection in the Environmental Lab appeared to significantly reduce the levels of interference during the last part of the monitoring activity.

It should be noted that the monitoring was conducted over a three-day period during which time there was only limited availability of an actual operational test system. With the limited monitoring data available all that can be concluded is that there are active interference signal paths in the ATE Lab area and that the equipment ground system of the electrical distribution system is the principle pathway.

The results from the spectrum analyzer (SA) were not remarkable.

The following two figures, 10 and 11, are waterfall plots of the recorded data from the spectrum analyzer. Each trace represents a peak-hold from a 5-minute period of time. The red highlighted signals represent levels 10% above the average. The frequency spectrum (x-axis) events are grouped on the left side (lower frequency) and are consistent with the frequency characteristics of the recorded signals. (Note: The 3dB bandwidth of the current probe used is 10kHz to 100MHz so the few signals above 100 MHz are not represented accurately.)

The signals represented by these graphs are being conducted through the LT flexible conduit connection to the test systems and may not be representative of the signal levels in other parts of the facility. Also the duration of the monitoring period was short and the recorded information may not represent conditions when other nearby labs are running experiments.

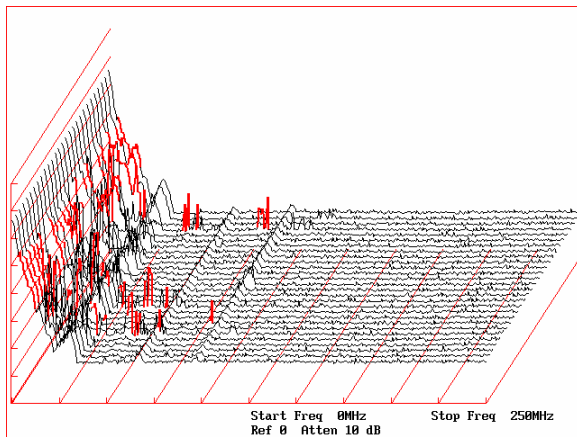

Figure 10 – Spectrum analyzer waterfall plot from initial monitoring session on 4/25/2000.

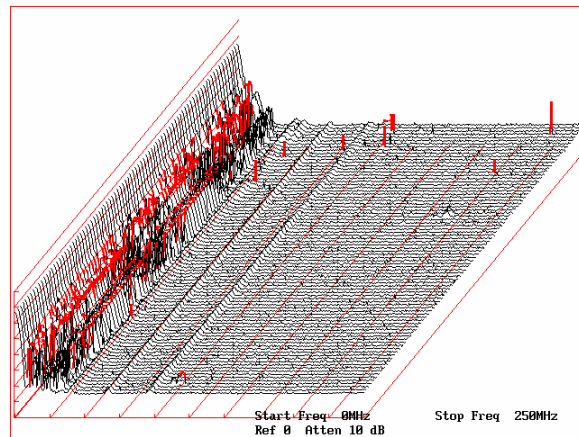

Figure 11 – Spectrum analyzer waterfall plot from 4/25/2000 @ 1:43PM through 4/26/2000 @ 9:43AM.

4. UPS Voltage Quality

As a byproduct to the monitoring of the electrical system in the ATE Lab at panelboard D40 a profile of the USP 208/120V electrical system was obtained. The following problems were noted with respect to the quality of the voltage supply.

Phase Voltage Unbalance

The following graphic, Figure 12, is a record of the phase voltage unbalance recorded at panelboard D40 in the ATE Lab area. Generally voltage unbalance levels above 3% are considered points where corrective action is recommended. Voltage unbalance as low as 2% can impact the operation of some motor drives. Higher levels of unbalance can cause premature electric motor failure or inconsistent operation.

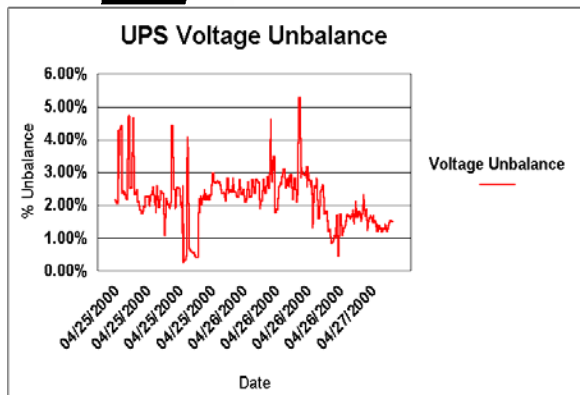

Figure 12 – UPS voltage unbalance.

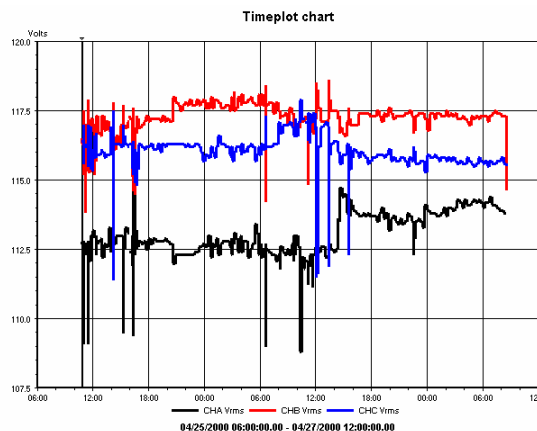

Figure 13 – RMS voltage timeplot.

Figure 13 (above) is a timeplot of the RMS voltage levels recorded at panelboard D40 over the duration of the monitoring period, which was the basis for the unbalance calculations illustrated in Figure 12.

Voltage Harmonic Distortion (Vthd)

The voltage waveform distortion of the UPS power system is excessive.

During the monitoring period the Vthd ranged from 11% to over 14%. A level of between 6% and 10% is generally considered the area where corrective action is recommended. The dominant cause of the voltage distortion is the load interaction between the single-phase switch-mode power supplies (computer type loads) and the output impedance of the UPS inverter section. Figure 14 is a timeplot of the voltage total harmonic distortion (THD) over the duration of the monitoring period. Figure 15 is a representative sample of the voltage waveform demonstrating both the phase unbalance and the waveform distortion.

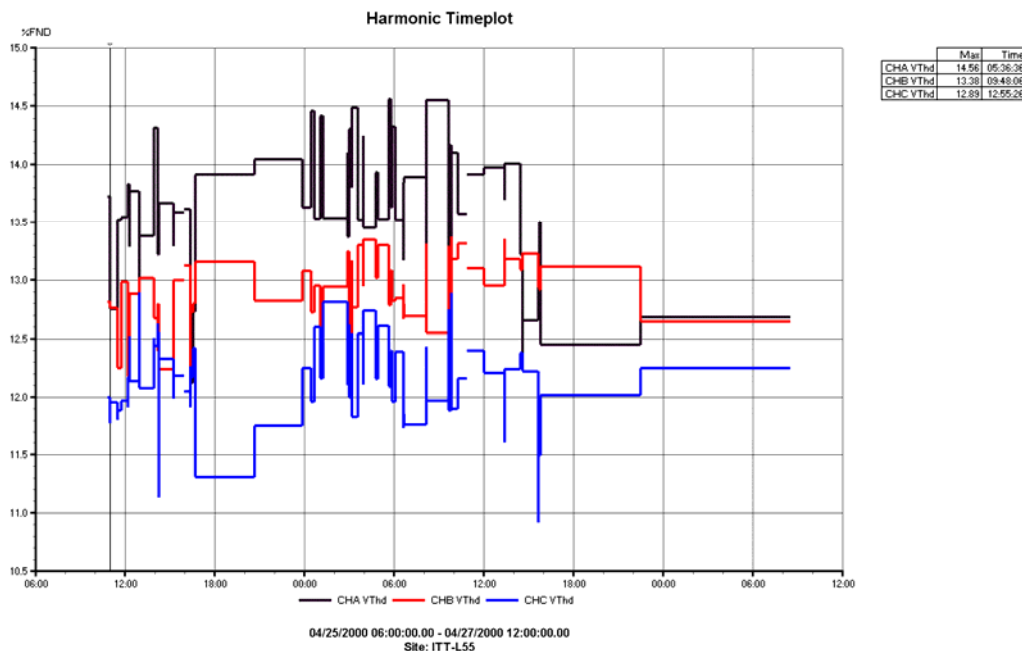

Figure 14 – Voltage distortion timeplot.

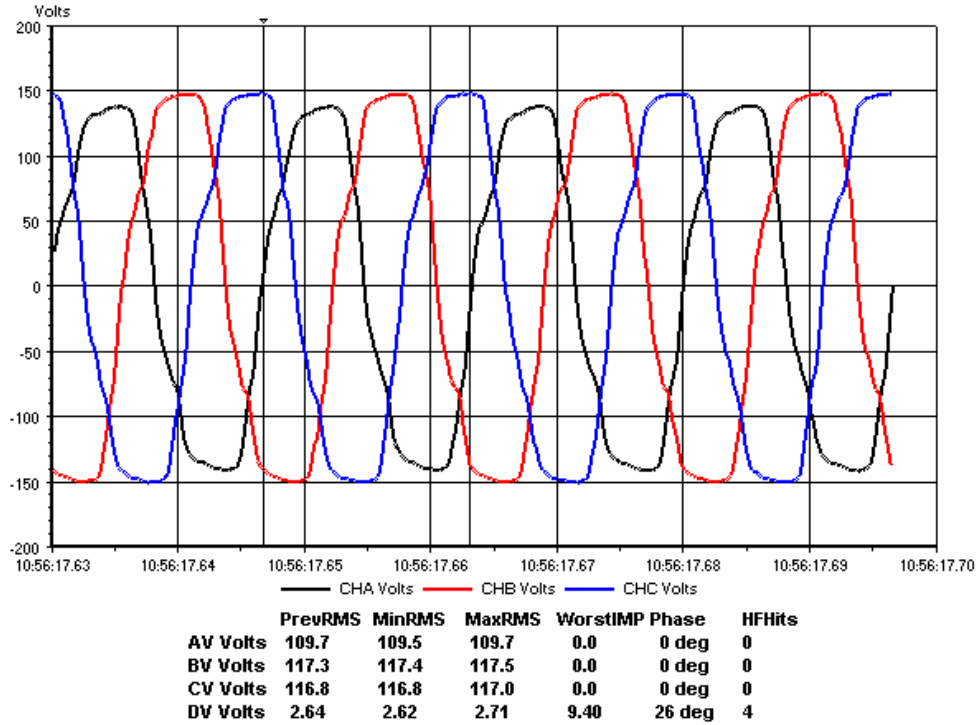

Figure 15 – Voltage waveforms showing phase unbalance and waveform distortion.

Excessive voltage distortion consumes capacity in the electrical distribution—wasted energy. In addition it can cause problems for magnetic equipment—motors, transformers, etc.—resulting in decreased performance or premature equipment failure.

The peak value of the 120Vrms supply is approximately 150Vpeak, which is a 12% decrease in voltage available to drive the various electronic loads.

Some of the distortion may be the result of the bad output filter capacitors on the Exide UPS.

Other Items

The following figure is a recording of the current flow in the TTL data link that seems to coincide with energizing the interface—see Figure 16. The signal is only present on channel associated with the TTL data link and was recorded by the monitoring equipment on several occasions when the interface was activated. This is probably a normal situation associated with the testing process and not associated with the communications problems being experienced at other times.

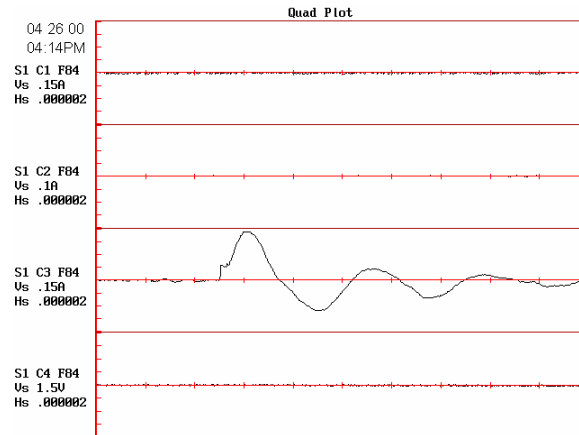

Figure 16 – TTL data link event at time of interface activation.

Recommendations

A. Facility Electrical Distribution Design

All future construction specifications for the buildings electrical distribution system should specify that appropriately sized ground conductors be installed in all conduits along with the current carrying conductors. This serves two purposes: (1) in the event of electrical faults on an associated circuit the equipment grounding conductor will carry the highest level of fault current and limit (lower) the propagation of interference signals in the remainder of the conduit system and (2) the quality of the equipment grounding system will be improved as the integrity of the system will no longer depend on screw-thread, clamp and compression sleeve connections as the only ground means.

Future building specifications for electronic environments should also include the requirement for equipment ground conductors—specifically, do not rely on conduit only grounding. Electrical distribution for all future construction should employ dry-type delta-wye distribution transformers to create zones of interest, and limit interference and zero-sequence harmonics from propagating throughout the buildings electrical distribution. The transformer requirement is especially critical for laboratory—ATE, Environmental, EMC, etc.—areas which all should be served from individual transformers. (See recommendation for ATE Lab below.)

B. Branch Circuit Installation Practices

The practice of installing branch circuits where they originate in one lab (sensitive area) and terminate in another lab—as was the case with the IG circuits 22-24-26 in panelboard D40 (ATE Lab)—should be avoided. Installing circuits, which run between zones of interest compromise the electrical integrity (at least from an interference standpoint) of both lab areas.

C. ATE Lab Electrical Environment

The existing electrical environment for the ATE Lab is not capable of supporting sensitive electronic system testing. The buildings equipment grounding system—part of the electrical distribution system—utilized a conduit only configuration. While this is electrical code compliant from a fire and life safety perspective is not sufficient for the type of activities being performed in many of the lab areas.

The objective of any mitigation activity should be to establish a separately derived electrical supply serving the electronic test systems in the ATE Lab. Further it will be necessary to insulate the electrical distribution connected to the test bays from the building conduit system. This program can best be accomplished through the installation of an isolating—delta-to-wye transformer—Power Distribution Unit (PDU) adjacent to the D40 panelboard. The electrical distribution on the secondary of the PDU should be via liquid tight flexible conduit—care should be taken to ensure that the PDU distribution does not come in contact with the building conduit system or other extraneous grounds.

The PDU equipped with the delta-wye transformer provides for a neutral-ground bond on the secondary as well as a capacitive filter output to attenuate transients and load interaction within the ATE Lab area.

Figure 17 below is a diagram of the proposed electrical distribution for the ATE Lab.

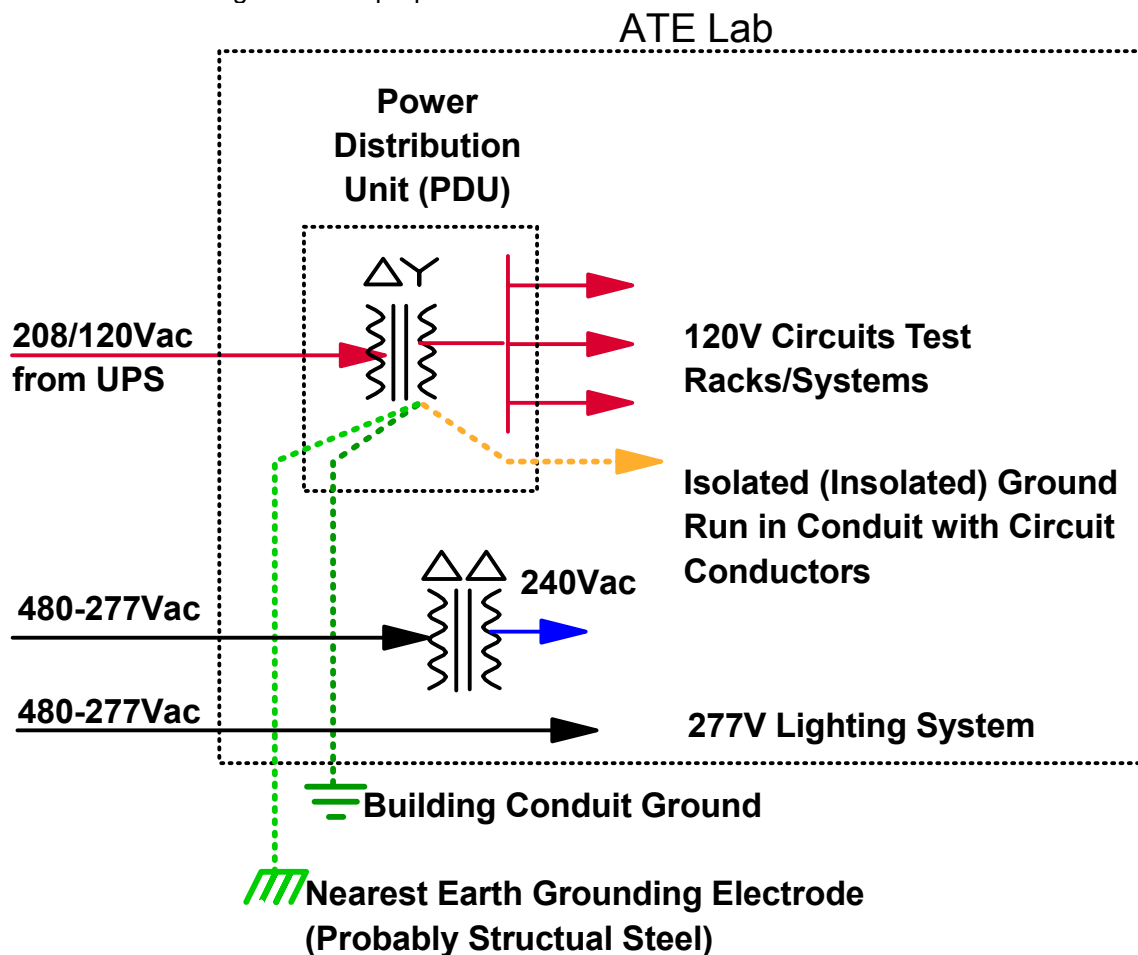

Figure 17 – Proposed electrical distribution for ATE Lab with PDU.

In addition to providing noise filtering and a new electrical system reference (neutral-ground bond) the delta-wye transformer in the PDU will provide some harmonic relief to the Exide UPS equipment. The zero sequence harmonics (3rd, 9th, 15th, etc.) are converted to balanced harmonics, dominantly 5th and 7th, through the phase relationships between the delta primary and wye secondary.

Monitoring of the ATE Lab electrical environment should be scheduled following installation of the PDU and associated distribution circuits to verify the noise performance of the new electrical configuration and to determine if any local interference sources are exists in the lab area.



C. UPS Voltage Distortion and Unbalance

A more detailed evaluation is required before a determination can be made as to the cause of the excessive voltage distortion and phase voltage unbalance—they may be inter-related. In all probability, both are likely do to the harmonic nature of the loads and, to some extent, the age of the UPS equipment.

Action plan for UPS power system evaluation:

- Inspect and test UPS output filter capacitors—infrared thermography can sometimes be used to ascertain the condition of the filter capacitors (look for the cold ones).
- Monitor and determine phase voltage unbalance levels at UPS output and verify load balance on major UPS distribution feeders.
- Review loads connected to UPS power system—remove non-critical loads that do not require UPS power.
- Monitor and determine harmonic content at UPS output—voltage and current.
- Based on findings from above activities develop a mitigation program to improve (decrease) harmonic voltage distortion and restore phase voltage balance.

Summary

ATE Lab

The limited monitoring has demonstrated that active interference paths are present that have the ability to conduct high frequency interference signals into the ATE Lab test stations and through the TTL data link. The building equipment grounding (conduit) system is the principle contributor to this situation.

The design of the buildings electrical distribution (and grounding) system does not provide any type of isolation between the various power systems and associated noise sources and the electronic test systems. In addition little, if any, transformer isolation is used in the various power systems.

To provide immediate relief to the ATE Lab test facilities an isolating PDU has been recommended with the secondary distribution being isolated (insulated) from all contact with the building conduit system. The PDU provides for a separately derived source—neutral-ground bond—in close proximity to the test equipment and combined with the capacitive output filtering should help to eliminate (or limit) the propagation of interference.

Follow-up monitoring should be scheduled following completion of the installation of the PDU and electrical distribution circuits to verify performance and identify any interference sources in the lab area.

ABC may want to consider similar installation of isolating PDUs in other lab areas to provide the proper electrical environment and prevent similar problems in the future.

UPS Power

During the monitoring process the quality of the UPS voltage supply was evaluated and two problem areas were identified for future consideration.

UPS Output Voltage Unbalance

The first item is the voltage unbalance between phases, which is nominally between 2% and 3%-- normally an action level. Peak levels of voltage unbalance as high as 5% were recorded during the monitoring period.

For single-phase loads the voltage unbalance does not pose a problem, but in the case of any 3-phase motor and motor drives the problem can become severe. Typical problems resulting from the unbalance are erratic equipment operation, insufficient starting torque, premature motor failure (over heating) and motor drive dropout or other performance issues.

The cause of the voltage unbalance is most likely a single-phase load condition where one, or more, phases have excessive single-phase loads connected. It could also be a problem with the UPS output inverter and/or filter capacitors.

UPS Voltage Harmonic Distortion (V_{thd})

The second item noted during the monitoring was excessive voltage distortion. The distortion levels are running between 11% and 14%, which is well beyond the typical action level of 5%.

Excessive harmonics consume capacity in the USP distribution system—i.e., efficiency issue—as useful energy is only consumed the fundamental frequency, 60Hz. Correcting harmonics in this type of distribution can reclaim significant levels of electrical capacity and differ future capacity build-outs.

In addition to the energy efficiency issues the harmonics adversely impact other operating equipment—motors, motor drives, power supplies, etc.—through insufficient voltage supply, phase angle errors (motor drive operation) and over heating in motor windings and transformers.

In all likelihood the harmonic distortion is the result of the large number of single-phase electronic loads connected to the UPS output distribution and the lack of any transformer conversion, which would help to limit the propagation of zero sequence harmonics.

A harmonic study will be required to determine the specific cause of the distortion and provide information for evaluating various mitigation options. Any study should include an evaluation of the service life for the existing UPS equipment and consideration of the replacement UPS as part of a harmonic mitigation plan. It may be more cost effective to delay significant harmonic mitigation until the change out of the existing UPS equipment and then switch to a 480V UPS model and use 480-208/120V delta-wye distribution transformers to control zero sequence harmonics and limit propagation of interference in the general facility.

General

Future consideration should be give to changing facility design specifications to require equipment-grounding conductors in conduits with the circuit conductors. This would improve the overall quality of electrical system grounding and help control fault currents to the circuits directly associated with the problem area.

An additional area of consideration should be review of lightning protection issues associated with the Somewhere Valley facility. Specific areas of concern are: power entrances, telecommunications facilities and roof mounted communications and security equipment.

Report prepared by:

Bruce Lonie
President, PowerCET Corporation